



Sweepers & Sweeper Collectors



Standard Specification

- Sweep and collect in one operation
- Sweeper mounted on a heavy-duty hydraulic link box
- Sweeper and link box can be separated to use as a standard link box
- Quick attach bar included with link box
- Hardened wear edge as standard
- 35 l/min hydraulic oil flow requirement
- Galvanised canopy as standard
- Sweeper parking stands
- Various bristle segment combinations available:

Polypropylene and steel mix
All Polypropylene

Optional Extras

- Kerb brush
- Dust suppression dribble bar





MODEL	LINK BOX WIDTH	BRUSH WIDTH	LINK BOX VOLUME
6' 10" (2.08m)	2035mm	1830mm	0.57m ³
7' 10" (2.38m)	2340mm	2135mm	0.66m ³
8' 10" (2.69m)	2640mm	2440mm	0.74m ³

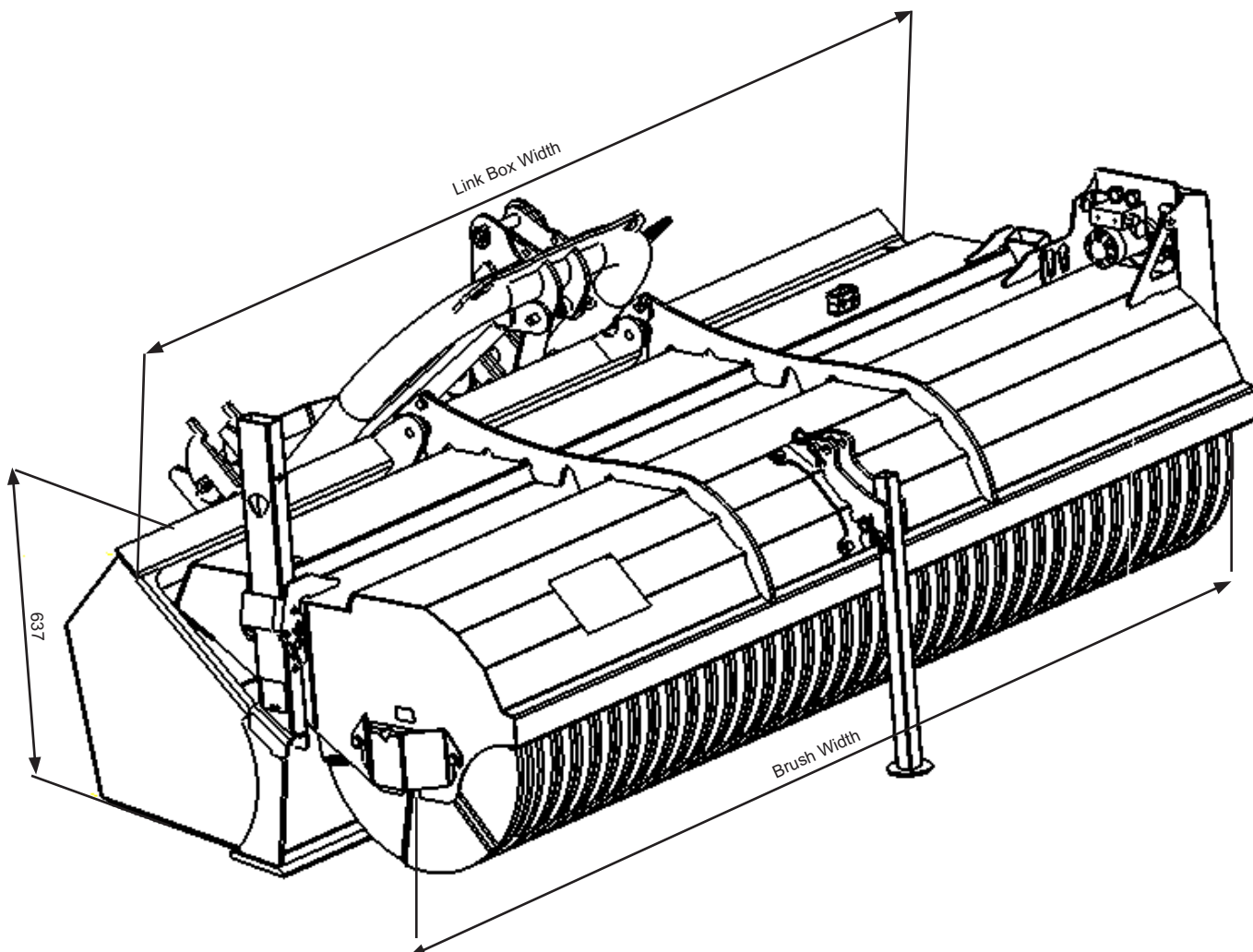

Standard Specification

- Angle operation possible to sweep either side
- 35 l/min hydraulic oil flow requirement
- Range of sweeping widths available:
 - 2.13m
 - 2.44m
 - 2.74m
- 22" (558mm) dia. bristles
- Various bristle segment combinations available:
 - Polypropylene and steel mix
 - All Polypropylene
- 3-point linkage attachment c/w reversible jacks & pneumatic wheels
- Front or rear mounted operation

Optional Extras

- Adaptor plate c/w brackets for telehandler/loader attachment



Standard Specification

- Sweep and collect in one operation
- 35 l/min hydraulic oil flow requirement
- Bucket supplied with hardened wear edge as standard
- Range of telehandler/loader brackets available
- Range of sweeping widths available:
 - 2.13m (7')
 - 2.36m (7'9")
 - 2.66m (8'9")
- Custom sweeper size available to suit existing buckets
- Brush rotor chain driven for reliable operation and for closer operation to walls/kerbs (when compared to a direct drive machine)
- Hydraulic motor mounted on top of sweeper canopy to reduce risk of damage
- Various bristle segment combinations available:
 - Polypropylene and steel mix
 - All Polypropylene

Optional Extras

- Dust suppression dribble bar





MODEL	BUCKET WIDTH	BRUSH WIDTH	BUCKET VOLUME
7' (2.13m)	2155mm	1905mm	0.88m ³
7'9" (2.36m)	2385mm	2135mm	0.92m ³
8'9" (2.66m)	2690mm	2440mm	1.11m ³

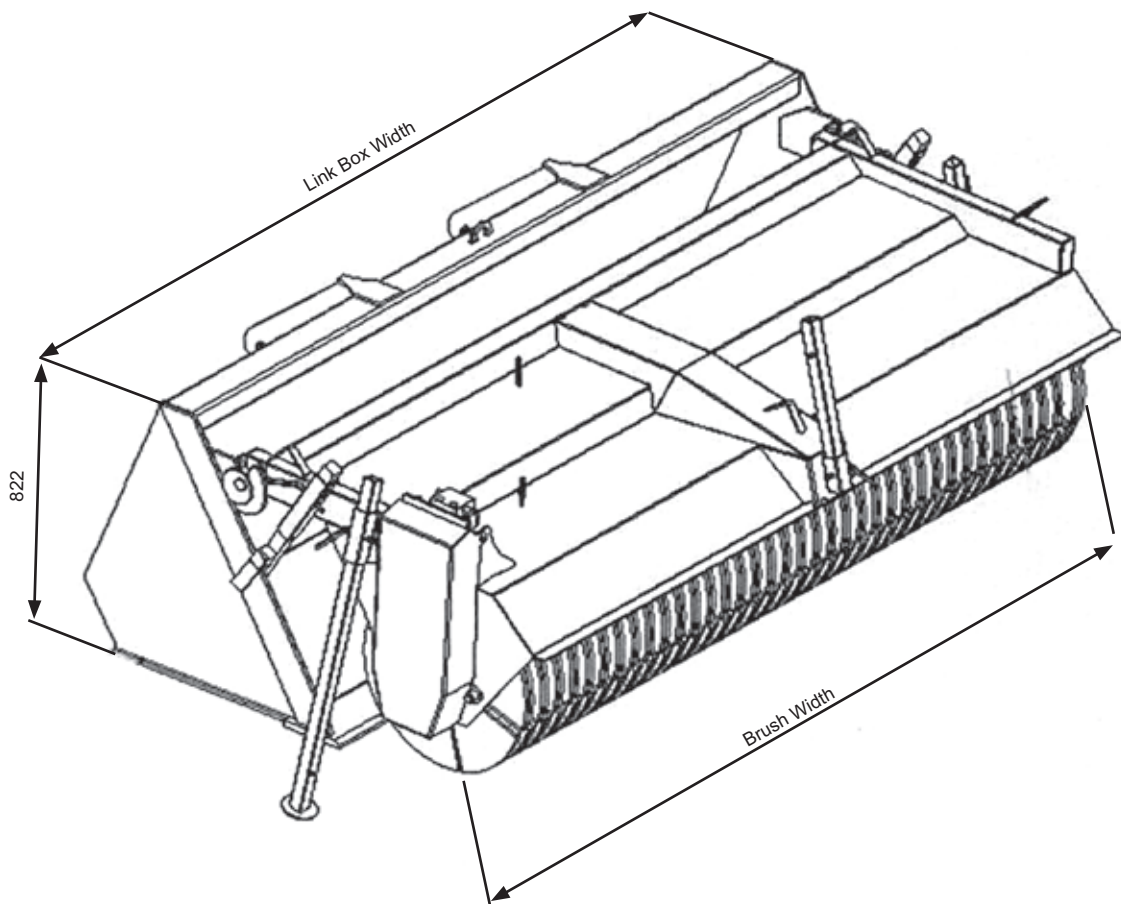

Standard Specification

- Sweep and collect in one operation
- 35 l/min hydraulic oil flow requirement
- Bucket supplied with hardened wear edge as standard
- Supplied as standard on New Holland type brackets
- Range of sweeping widths available:
 - 1.67m (5'6")
 - 1.83m (6')
- Brush rotor chain driven for reliable operation and for closer operation to walls/kerbs (when compared to a direct drive machine)
- Hydraulic motor mounted on top of sweeper canopy to reduce risk of damage
- Various bristle segment combinations available:
 - Polypropylene and steel mix
 - All Polypropylene

Optional Extras

- Non-standard skid steer brackets



Standard Specification

- Heavy-duty galvanised steel construction
- Push brush – no moving parts
- Integrated parking stands for storage
- Range of sweeping widths available:
 - 2m
 - 2.5m
 - 3m
- 11 rows of quick-change bristles
- Low dust creation
- Easy clean design

Optional Extras

- Bucket attachment
- Tractor 3-point linkage (a-frame)
- Mounting plate for customer to weld excavator brackets
- Standard and non-standard handler brackets

