

Grain/Silage Trailers



Standard Specification

- Sprung drawbar c/w heavy duty EN16 towing eye
- 10-stud commercial axles
- Hydraulic brakes giving minimum 35% braking efficiency.
- Mono leaf parabolic suspension at wide centre for maximum stability.
- Ratchet Handbrake
- Full R.T.A LED lights with progressive indicator
- LED high level lights
- LED flasher
- Twin tipping rams for more stable tipping 50 degree tipping angle
- Hydraulic up and over grain door
- Full width Perspex front window c/w arch
- 70mm taper on body
- Galvanised side access ladder
- Rope hooks
- Sockets for fitting silage sides, roll over cover etc
- Front and rear mudflaps
- Side and rear reflective tape
- Grain Chute blanking plate
- ¾" tipping hose
- 445/65 R22.5 Wheels (Tandem)
- 560/60 R22.5 Wheels (Triaxle)
- Self Steer Axle (Triaxle)





14 – 26 tonne models with large capacity body manufactured with one piece floor to optimise strength.

Twin tipping cylinders provide stability and raise tapered body to 50° for easy material flow





Hydraulic Tipping Safety Switch



Access Ladder



High and Low Level Rear LED lights



Twin Tipping Ram



Perspex Window And Front Mud Flaps



Reflective Tape

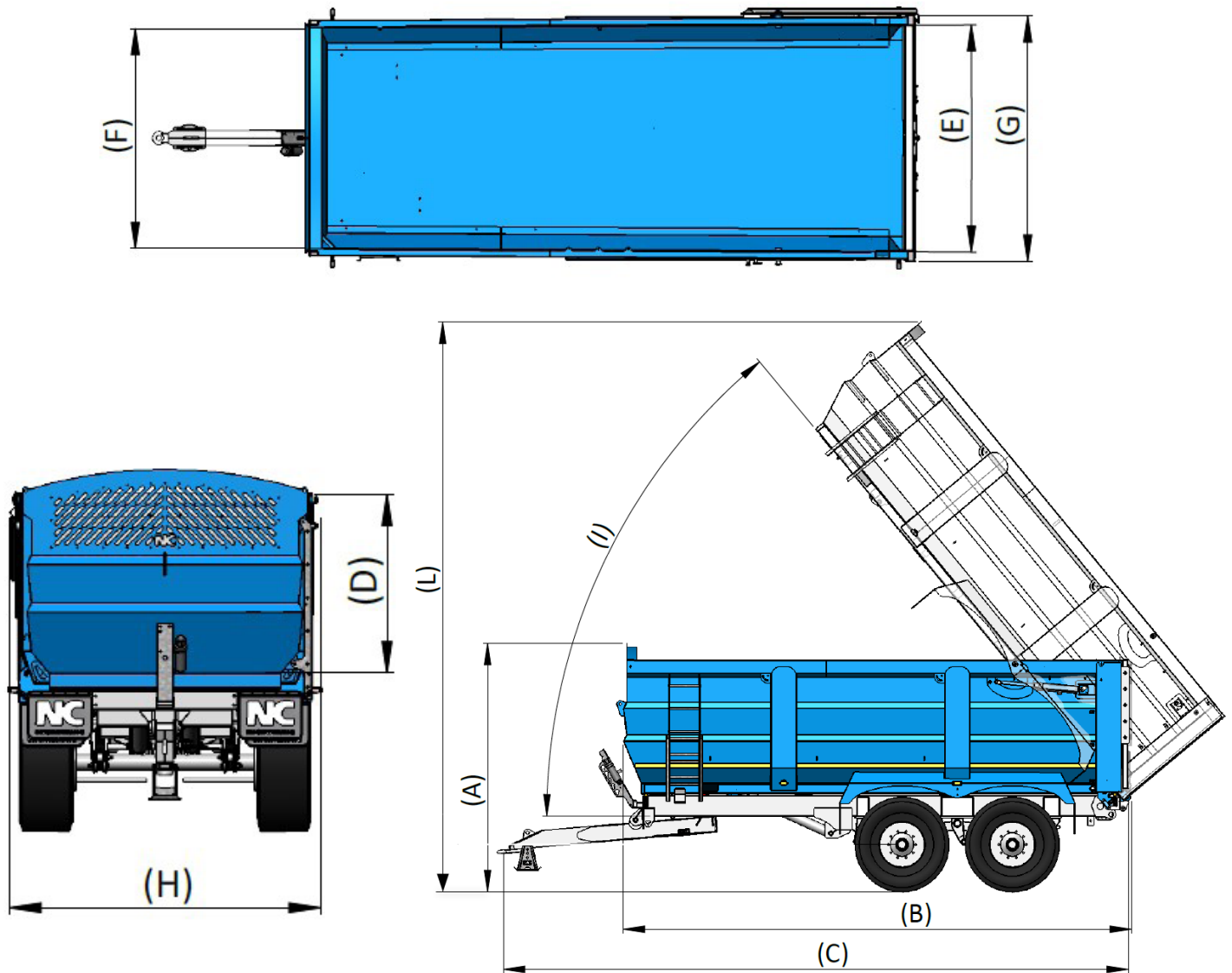

		Silage Trailers					
	Units	1850-14	2050-16	2250-18	2450-20	2460-24	2660-26
Overall height body down (A)	m	3.05	3.05	3.05	3.05	3.2	3.2
Overall height body down with silage kit	m	3.75	3.75	3.75	3.75	3.9	3.9
Overall Body Length (B)	m	5.64	6.25	6.82	7.42	7.71	8.32
Overall Length (C)	m	7.14	7.75	8.36	8.97	8.97	9.58
Floor to top of side, Internal (D)	m	1.51	1.51	1.51	1.51	1.82	1.82
Floor to top side with silage kit, Internal	m	2.42	2.42	2.42	2.42	2.52	2.52
Inside width of body rear (E)	m	2.3	2.3	2.3	2.3	2.3	2.3
Inside width of body front (F)	m	2.23	2.23	2.23	2.23	2.23	2.23
Outside width of body (G)	m	2.49	2.49	2.49	2.49	2.49	2.49
Overall width (H) Inc Hydraulic Door	m	2.62	2.62	2.62	2.62	2.62	2.62
Tipping angle (I)	°	50	50	52	50	50	50
Overall tipped height (L)	m	6.49	6.96	7.54	7.79	8.22	8.69
Overall tipped height with silage kit	m	7.12	7.59	8.16	8.43	8.7	9.13
Oil required to tip	Litres	32	37	53	53	53.5	53.5
Number of axles	Qty	2	2	2	2	3	3
Volume	m ³	19.3	21.4	23.6	25.8	31.4	34
Volume with silage kit	m ³	35	38.7	42.7	46.6	48.8	52.9
Tyres	Type	445/65 R22.5	445/65 R22.5	445/65 R22.5	445/65 R22.5	560/60 R22.5	560/60 R22.5



Plastic lockable toolbox



Foldable rear tow hitch



Grain Chute Extension with sock



Grain Chute



Full length rear mudflap



Silage Sides

Wheels

Description	1650-13	1850-14	2050-16	2250-18	2450-20	2460-24	2660-26
445/65 R22.5 Remould	Std	Std	Std	Std	Std		
445/65 R22.5 New	•	•	•	•	•		
560/45 R22.5 BKT Ridemax	•	•	•				
560/60 R22.5 Alliance	•	•	•	•	•	Std	Std
560/60 R22.5 BKT Ridemax	•	•	•	•	•	•	•
600/50 R22.5	•	•	•	•	•	•	•
650/50 R22.5	•	•	•	•	•	•	•

Optional Extras

General

Roll over cover c/w long winding handle
Foldable rear tow hitch c/w light socket
Full length rear mudflap
Rear underrun c/w mudflap
Fixed rear rescue point
Self-steering axle (Standard on Tri-Axle)
Grain chute
Grain chute extension c/w grain sock
Lockable Plastic toolbox
Side impact protection
Transcover to suit both grain and silage kit options
Door Seal
Standard colours NC: Red (RAL 3001), Green (RAL 6001), Blue (RAL 5005).
For other colours RAL must be specified
Central greasing points for suspension and axles
Command Steering

Brakes

Dual air hydraulic brakes
Air only brakes
Hydraulic loadsensing
Air loadsensing
12volt ABS c/w Susie
Automatic slack adjusters
ABS ready kit
NC cable breakaway

Brakes continued -

Revision.06 June 24

In accordance with our policy of continued development we reserve the right to alter specification and design without notice.



NC Engineering (Hamiltonsbawn) Ltd
2 Killyrudden Road
Hamiltonsbawn
Co. Armagh
Northern Ireland
BT61 9SF

Tel: 028 38 871970
Fax: 028 38 870362

www.nc-engineering.com

NC electric breakaway
Eurosafe breakaway
Powerbrake in lieu of standard handbrake
Hydraulic brake connection on rear of trailer
Air brake connection on rear of trailer
Premium red and yellow Susie c/w handle grips
(Dual or air brakes only)

Silage Sides

2ft (610mm) x 3ft (914mm) Silage Extension Sides (Tandem)
3ft (914mm) Silage Extension Sides (Tandem)
700mm Silage Extension Sides (Triaxle)

Electrics

Reversing camera
2x front and rear LED work lights
2x front and rear LED worklights activated by switch as body tips
Side marker lights flashing as indicators

Warning Signs

Long Vehicle signs (legal requirement for tractor & trailer 13m+ in ROI)
EU slowing vehicle warning triangle
Side and Rear Reflective Tape

Towing Eye

Adjustable Hitch (not available with swivel)
K80 weld-on spoon
K80 bolt-on spoon
Bolt-on 50mm agri towing eye
Bolt-on 50mm Commercial towing eye
High hitch point on drawbar (650mm Max)
Towing Eye locking system

Parking Stand

Screw jack (commercial type)
Hydraulic jack

